



CASH VALVE SERIES 2300 SHORT-STEM SHUT-OFF VALVE INSTALLATION, OPERATING AND MAINTENANCE INSTRUCTIONS

Before installation, these instructions must be read carefully and understood.



1 DESCRIPTION

The Series 2300 short stem shut-off valve is designed for shut-off of liquid or gas service. The construction is designed specifically for cold gases or liquids with temperatures down to -320°F.

It has a bead-seat design for dead tight shut-off and an ergonomic handwheel which allows for low torque shut-off. The packing design combines low turning resistance with superior sealing.

2 SPECIFICATION DATA

Service:	CO ₂ , N ₂ , O ₂ , air, water or compressed air
Sizes:	1/4", 3/8" and 1/2"
Connections:	NPT, SBP, BSPT, BSPP (Also available: 0.675 and 0.840 O.D. tube inlets and outlets, contact factory for details)
Temp. rating:	- 320°F to +200°F (-195°C to 93°C)
Max. working pressure:	700 psig (48.2 bar)
Capacity:	A C _v factor of 1.3 applies to the 1/4" size and a C _v factor of 2.0 applies to 3/8" and 1/2" sizes

3 GENERAL INSTALLATION INSTRUCTIONS

Direction of flow through the valve is indicated on the valve body.

Inlet pressure is to be connected to the side of the body with the blunt end of the arrow.

The outlet is to be connected to the side of the body with the point of the arrow.



Torque valve connections enough to ensure a pressure-tight seal.

4 OPERATING INSTRUCTIONS

To open the valve

Turn handwheel counter clockwise (as viewed from top of valve).

Do not exceed 25-in/lbs. (2.8 Nm) torque when fully opened.

To close the valve

Turn handwheel clockwise until shut. Do not exceed 100 in/lbs. (11.3 Nm) torque.

CAUTION

Exceeding maximum rated torque values or any other listed specification limit voids the manufacturer's warranty and releases the manufacturer of all liability.

CASH VALVE SERIES 2300 SHORT-STEM SHUT-OFF VALVE

INSTALLATION, OPERATING AND MAINTENANCE INSTRUCTIONS

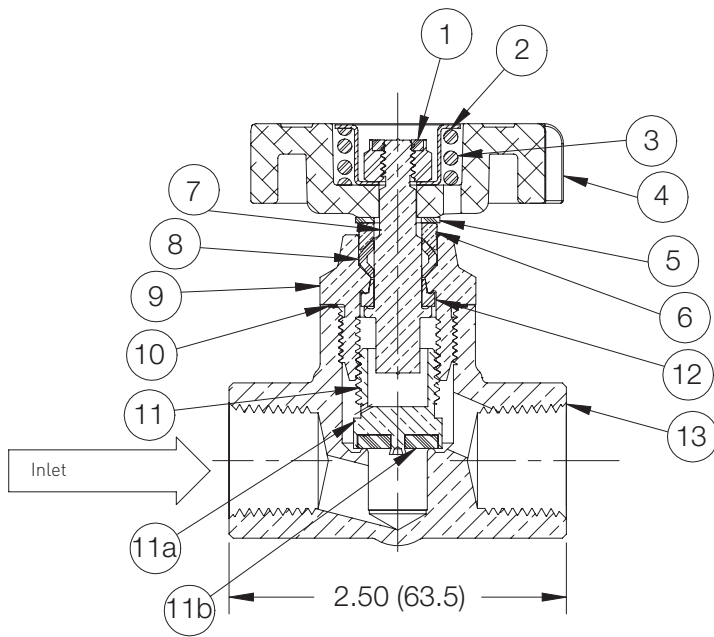

PARTS LIST

No.	Description	Material
1	Nut	SST
2	Spring button	Brass
3	Spring	SST
4	Handwheel	Aluminum
5	Washer	PTFE
6	Gland	Brass
7	Stem	Brass
8	Packing	PTFE
9	Bonnet	Brass
10	Gasket	Copper
11	Piston sub	
11a	Piston	Brass
11b	Seat disc	Kel-F
12	Seal	PTFE
13	Body	Brass

5 MAINTENANCE INSTRUCTIONS

CAUTION

Before attempting to replace any spare parts be sure to shut off all pressure connections to the valve.

See repair kit parts instructions specific to valve under maintenance.

6 CONSTRUCTION

See component description for materials of construction.

All parts are commercially cleaned for cryogenic service.

More information is available at Emerson.com/FinalControl

Neither Emerson, Emerson Automation Solutions, nor any of their affiliated entities assumes responsibility for the selection, use or maintenance of any product. Responsibility for proper selection, use, and maintenance of any product remains solely with the purchaser and end user.

Cash Valve is a mark owned by one of the companies in the Emerson Automation Solutions business unit of Emerson Electric Co. Emerson Automation Solutions, Emerson and the Emerson logo are trademarks and service marks of Emerson Electric Co. All other marks are the property of their respective owners.

The contents of this publication are presented for informational purposes only, and while every effort has been made to ensure their accuracy, they are not to be construed as warranties or guarantees, express or implied, regarding the products or services described herein or their use or applicability. All sales are governed by our terms and conditions, which are available upon request. We reserve the right to modify or improve the designs or specifications of such products at any time without notice.

Emerson.com/FinalControl